

STANDARD AFM® / SAND FILTERS

AFM®/P SERIES Ø 520-960



Ref	ID	Ø D	H	O	M	A	B	I/O	Filt. Surface	AFM® G3 / G2 / G1 (21 Kg) Sand(2-3/0.7-1.2/0.4-0.8)(25 Kg)
112352.X	AFM/P-520	520	1400	190	305	405	190	2"	0,20 m ²	0 / 2 / 7
112364.X	AFM/P-640	640	1440	190	305	420	190	2"	0,30 m ²	0 / 5 / 10
112372.X	AFM/P-720	720	1440	190	305	420	190	2"	0,40 m ²	0 / 5 / 13
112384.X	AFM/P-840	840	1460	190	305	440	190	2"	0,52 m ²	0 / 7 / 18
112396.X	AFM/P-960	960	1520	205	355	440	250	2 ½"	0,70 m ²	0 / 10 / 25

AFM®/P SERIES 850 - 900 BED HEIGHT

ORIENTATION OPTIONS Dimensions in mm.

Design pressure 2,5 Kg/cm² | Test pressure 3,75 Kg/cm².
 Lateral access manhole.
 Nozzle plate steel reinforced filter.
 Complete nozzle plate reliability.
 Internal steel reinforced filter.
 Special diffuser for Sand / AFM®.
 Female threads (GAS) in GRP are part of the body.
 Large diameter internal piping designed for both Sand / AFM® requirements.
 Sight glass.

Pos 6 X=6 (Standard)

Pos 2 X=2

SIGHT GLASS ALWAYS INCLUDED

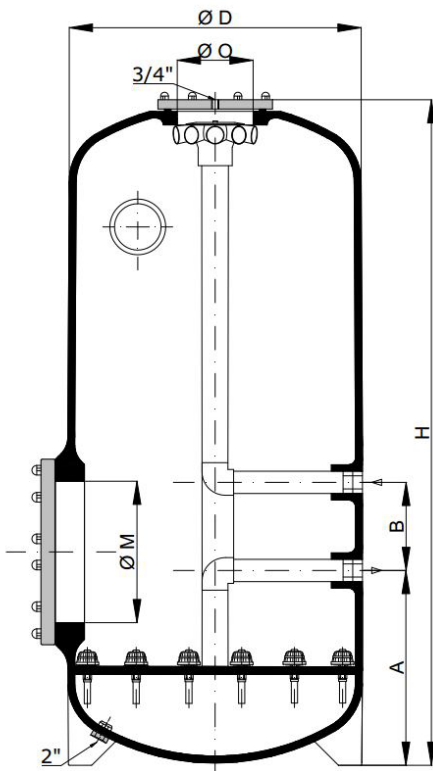

MANOMETER KIT INCLUDED



Optional
Manhole
&
Sightglass
Pos 2

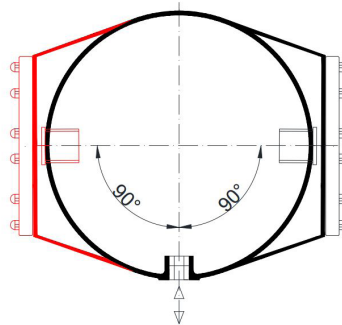

Standard
Manhole
&
Sightglass
Pos 6



Threaded connections
integrated in body

Transparent top lid

Access manhole

Top diffuser

Sight glass

Nozzle plate

Nozzle detail

Drain plug

